

Thank you for purchasing EBS Series Waterproof Column Speaker. In order to correctly use the device, please read the manual carefully.

If you have any questions or suggestions, please contact our local dealer.

### ■ Features

- EBS series are professional waterproof outdoor aluminum column speakers with 4-inch constant-voltage drivers
- Designed with all-weather materials, moisture-proof, waterproof and UV-resistant
- Drivers utilize 4-inch full-range moisture-proof and waterproof composite material diaphragm, producing warm sound and rich vocals
- Corrosion-resistant aluminum grille cover reduces weight and simplifies installation and maintenance

### ■ Applications

Various outdoor wall-mount applications (e.g., shopping malls, neighborhoods, stations, schools, parks, corporate units)

### ■ Technical Specifications

Product Type	Waterproof Column Speaker for Public Address		
Product Model	EBS-25W	EBS-45W	EBS-60W
Speaker Power(AES)	50W	90W	120W
Input Voltage	100V	100V	100V
Sensitivity	89dB	92dB	94dB
Frequency Response	100-16000Hz	100-16000Hz	100-16000Hz
Driver Quantity	1	2	3
Driver Dimensions	4 inches	4 inches	4 inches
External Dimensions (mm)	129X106X261	129X106X327	129X106X448
Installation Method	Wall mount	Wall mount	Wall mount
Mounting Accessory	L-shape brackets + pack of screws	L-shape brackets + pack of screws	L-shape brackets + pack of screws
Product Weight	1.5KG	2.17KG	2.95KG
IP Rating	IPX6		

### ■ Installation

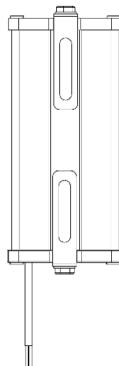
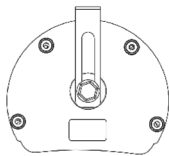
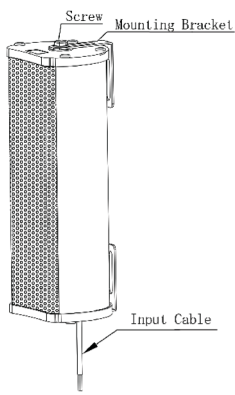

### ■ Illustration

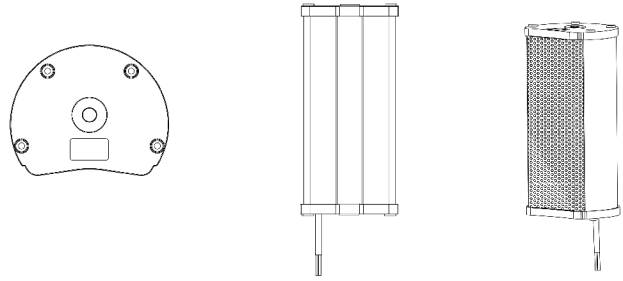

### ■ Dimensions

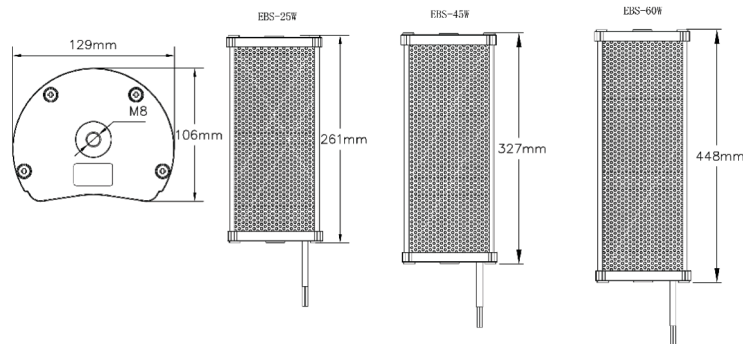

### ■ Safety Instructions

To avoid electric shock, overheat, fire, radiation, explosion, mechanical risk and injury or property loss due to improper use, please read and observe the following items before use:

1. Please check if the power of the connected equipment matches with that of this product before operation. Adjust the volume to proper level during operation. Do not operate at over-power or high-volume level for extended time to avoid product malfunction or hearing impairment.
2. If there is any abnormality during use (e.g., smoke, strange odor), please kill the power switch and unplug from power source, then send the product to the local dealer for repair.
3. Keep this product and its accessories in a dry and ventilated area. Do not store in a humid or dusty area for extended time. Keep away from fire, rain, liquid intrusion, bumping, throwing, vibrating, or from blocking any ventilation openings, to prevent malfunction.
4. The product must, when installed on walls or ceilings, be fixed firmly in place at adequate strength to prevent from falling.
5. Please abide by safety rules during operation. Do not use the product in places prohibited by laws or regulations to avoid accident.